

Design and Simulation of Active Cell Balancing using MATLAB/SIMULINK

P. Anil Kumar

Assistant Professor

Department of Electrical and Electronics Engineering (EEE)

Matrusri Engineering College

Hyderabad, Telangana, India

Email: anilkumar.palarapu@matrusri.edu.in

V. Sree Charan (1608-22-734-016)

Department of Electrical and Electronics Engineering (EEE)

Matrusri Engineering College

Hyderabad, Telangana, India

Email: cintuu1212@gmail.com

Qusai Yousuf Ahmed (1608-22-734-023)

Department of Electrical and Electronics Engineering (EEE)

Matrusri Engineering College

Hyderabad, Telangana, India

Email: qyousufahmed98@gmail.com

M. Srinivas (1608-22-734-326)

Department of Electrical and Electronics Engineering (EEE)

Matrusri Engineering College

Hyderabad, Telangana, India

Email: mengaramsrinivas@gmail.com

Abstract

The phenomenon of cell imbalance usually affects the performance of multi-cell energy storage devices, where variations exist in terms of cell voltage and SoC. It causes low efficiency and poor utilization of battery energy. Therefore, this paper explores an active cell balancing scheme to improve energy distribution and utilization within a cell. This paper proposes and analyzes the simulation of a cell balancing algorithm via the use of the MATLAB/Simulink modeling software package, considering multiple cells with various initial SoCs.

In order to equalize the charge distribution among different cells, the charging process involves transferring excessive charges from higher-energy cells to lower-energy cells. From the obtained results, it is clear that the disparity between the SoC values of cells reduces to zero, showing no sign of instability. Similarly, voltage differences have been minimized, which demonstrates successful redistribution.

It is evident that the proposed algorithm performs efficiently and reliably since the differences between the SoC values of various cells have reduced significantly to the point of reaching equality.

Keywords

- Active Cell Balancing
- State of Charge (SoC) Equalization
- MATLAB/Simulink
- Charge Redistribution

Section I - Introduction

In multiple cell batteries, achieving an equal distribution of charge between each cell remains one of the key issues. The reason behind this is that each cell might have different voltages and SoC due to production differences, temperature changes, and variations in their physical attributes. This will eventually result in imbalances and reduce energy efficiency.

The imbalance of cells leads to some cells having their maximum and minimum limits sooner than other cells, and thus the whole system will have its usable energy range limited by the earliest reaching cell limit. This affects both efficiency and reliability of the battery. Hence, the balancing of cells is very crucial.

The conventional balancing method, especially the passive balancing process, involves dissipation of the extra energy through heat loss, hence reducing the efficiency. Active cell balancing, on the other hand, is much better because it involves redistribution of charges from cells that have excess energy to cells that lack energy.

The implementation of an active cell balancing technique for the proposed system is done through MATLAB/Simulink. This technique takes into consideration any existing imbalance

between the cells and equalizes their states of charge by transferring charges. The performance of the technique is analyzed on its convergence, stability, and effectiveness.

In this paper, active cell balancing is discussed with its design in MATLAB Simulink software. The proposed system can balance out any initial imbalance existing amongst the cells while balancing them by transferring charge amongst the cells to bring their SoCs at par with one another.

Results show that the method works effectively to achieve equalization of the charge with stability. This research underscores the significance of using effective balancing techniques and serves as a base for future improvements and real-time application of more complex balancing methods.

SECTION II - Literature Review

Cell balancing has received considerable attention in recent times because of its role in ensuring equal charge sharing among individual cells. There are several different approaches described in literature, which can be categorized into two types: passive and active cell balancing strategies.

A passive balancing technique involves the use of resistors to dissipate any excess power from cells having higher voltages. The disadvantage of passive balancing is that it is very inefficient, as much of the power is lost in the process of balancing the cells. Passive balancing is only useful for charging cycles, and it does not increase the efficiency of power usage.

To address these shortcomings, active cell balancing strategies have been formulated. In such strategies, energy is transferred from high-energy cells to low-energy cells to optimize efficiency. According to the IEEE article, there are two broad categories of active balancing strategies:

1. Cell-to-cell energy transfer, which involves direct transfer of energy between cells
2. Cell-to-auxiliary energy transfer, which involves storing energy before redistributing it among cells

Of these two strategies, the latter strategy simplifies the circuit design without sacrificing energy transfer efficiency. In the suggested system in the reference article, the use of the switch matrix and forward converter topology enables efficient energy transfer with efficiencies of up to 90 percent when charging and 72 percent when discharging.

Despite these benefits, however, active balancing methods continue to suffer from some limitations. Firstly, most active balancing methods rely on control circuits, additional circuit components, and precision switching processes. Secondly, many active balancing methods incorporate several operating modes, resulting in greater energy losses and balancing times. Lastly, many active balancing methods rely on unique circuitry per cell, making them more expensive and complicated

2.1 Research Gap

Based on the literature review, the following research gaps have been identified:

1. The passive balancing approach is characterized by low efficiency and energy dissipation in the form of heat.
2. Currently, active balancing systems utilize complicated electronics and incur high costs.
3. Certain techniques need to operate under several modes, leading to losses in energy and time.
4. Few studies consider simplified simulations for proper verification.
5. Requirement of smooth balancing process without much difficulty in controlling.

2.2 Motivation of This Work

In order to mitigate these challenges, this study concentrates on building an active cell balancing simulation using MATLAB/Simulink with the following features:

1. Effective charge balancing.
2. Imbalance mitigation.
3. Stable and smooth convergence.
4. Easier implementation than hardware approaches.

Section III - Methodology/ Proposed System

3.1 System Design

The proposed system is designed to achieve active cell balancing between two cells using a MATLAB/Simulink-based model. The system consists of:

- Two cells with different initial State of Charge (SoC).
- A bidirectional DC-DC converter (inductor-based).
- Power electronic switches (S1 and S2).
- Diodes for controlled current flow.
- A control unit (MATLAB function block).
- PWM signal generator.

The control system continuously monitors the SoC of both cells and generates switching signals accordingly to enable charge transfer from the higher SoC cell to the lower SoC cell.

3.2 Block Diagram Explanation

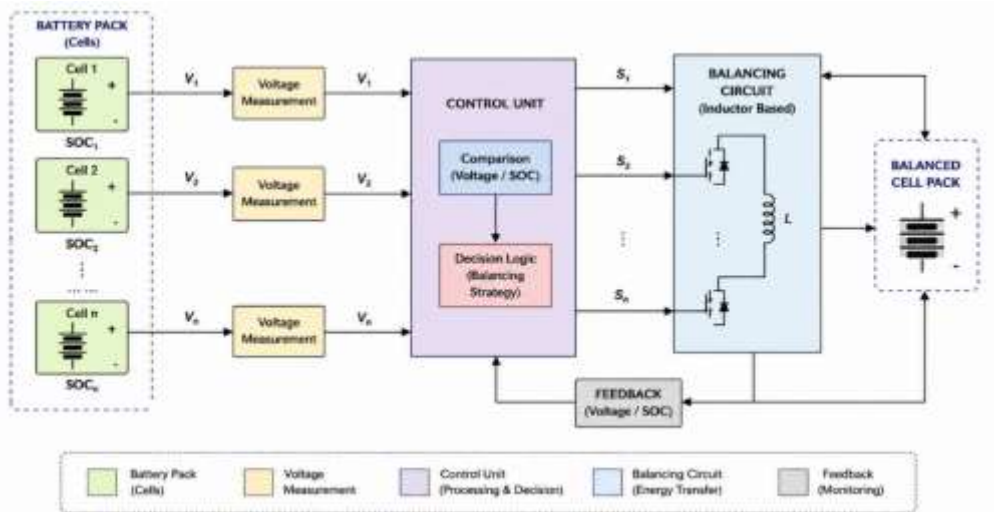

The proposed active cell balancing system consists of multiple cells, a measuring unit, a control unit, and a balancing circuit. **Figure-1 Block diagram of the proposed active cell balancing system.** The measured signals (Voltage / State of Charge) are sent to the control unit, where the comparison of voltage/SoC is performed to detect imbalance among the cells. From this comparison the decision logic determines the correct balancing action and generates control signals (S_1, S_2, \dots, S_n). These control signals drive the inductor based balancing circuit to transfer energy from higher energy cells to lower energy cells. The inductor is the primary energy transfer element and allows for efficient and controlled charge redistribution. Power electronic switches control the direction and amount of energy flow.

The measured signals are sent to the control unit, where the comparison of voltage/SoC is performed to detect imbalance among the cells. From this comparison the decision logic determines the correct balancing action and generates control signals (S_1, S_2, \dots, S_n).

These control signals drive the inductor based balancing circuit to transfer energy from higher energy cells to lower energy cells. The inductor is the primary energy transfer element and allows for efficient and controlled charge redistribution. Power electronic switches control the direction and amount of energy flow.

The latest voltage / SoC values are continuously fed back to the control unit through a feedback path, thus ensuring dynamic and stable operation. This continues until all the cells are pretty much equal. The system is balanced.

3.3 Working Principle

The proposed system works by continuously measuring the voltage or State of Charge (SoC) of each cell and exchanging energy to equalize it. The measured values are fed to the control unit. There, a comparison is made to detect imbalance.

The difference is used by the control unit to generate switching signals (S_1, S_2, \dots, S_n) for activating the balancing circuit. When a cell has higher energy, its corresponding switch is turned ON, permitting energy to be transferred to cells with lower energy through the inductor. The inductor temporarily stores energy and enables efficient transfer between cells.

The switching operation is controlled using PWM. The amount of energy transferred in each cycle is controlled by this. A feedback loop continuously feeds the latest measurements to the control unit, which allows a dynamic adjustment of the balancing process.

The operation is continued until the voltage or difference of SoC between the cells is less than a given threshold and the balanced condition is achieved.

3.4 Mathematical Modeling

The proposed active cell balancing system is modeled based on the inductor-based energy transfer mechanism and the difference in State of Charge (SoC) between cells.

The SoC of a cell is defined as:

$$SoC(t) = SoC(0) - \frac{1}{C} \int i(t) dt$$

where C is the cell capacity and i(t) is the cell current.

The imbalance between two cells is represented as:

$$\Delta SoC = SoC1 - SoC2$$

Balancing is initiated when $|\Delta SoC|$ exceeds a predefined threshold.

The inductor governs the energy transfer between cells. During switching operation, the inductor voltage is given by:

$$V_L = -L \frac{di}{dt}$$

where L is the inductance and i is the inductor current.

The energy stored in the inductor is:

$$U = \frac{1}{2} LI^2$$

During operation:

- When switch S1 is ON, energy is transferred from Cell 1 to the inductor.
- When switch S2 is ON, stored energy is delivered to Cell 2.

The average current transferred depends on the duty cycle D of the PWM signal, which controls the rate of balancing.

The balancing process continues until:

$$|SoC1 - SoC2| \leq \epsilon$$

where ϵ is the allowable threshold.

3.5 Control Algorithm

The control logic implemented in the MATLAB function block follows these steps:

Algorithm Steps

1. Measure SoC_1 and SoC_2 .
2. Calculate difference:
$$\Delta SoC = SoC1 - SoC2$$
3. Compare with threshold value:
 - If $\Delta SoC > \epsilon \rightarrow$ Activate S1

- If $\Delta\text{SoC} < -\epsilon \rightarrow$ Activate S2
 - Else \rightarrow Turn OFF both switches
4. Generate PWM signals for switching
 5. Continue until SoC difference becomes negligible

3.6 Flow Chart

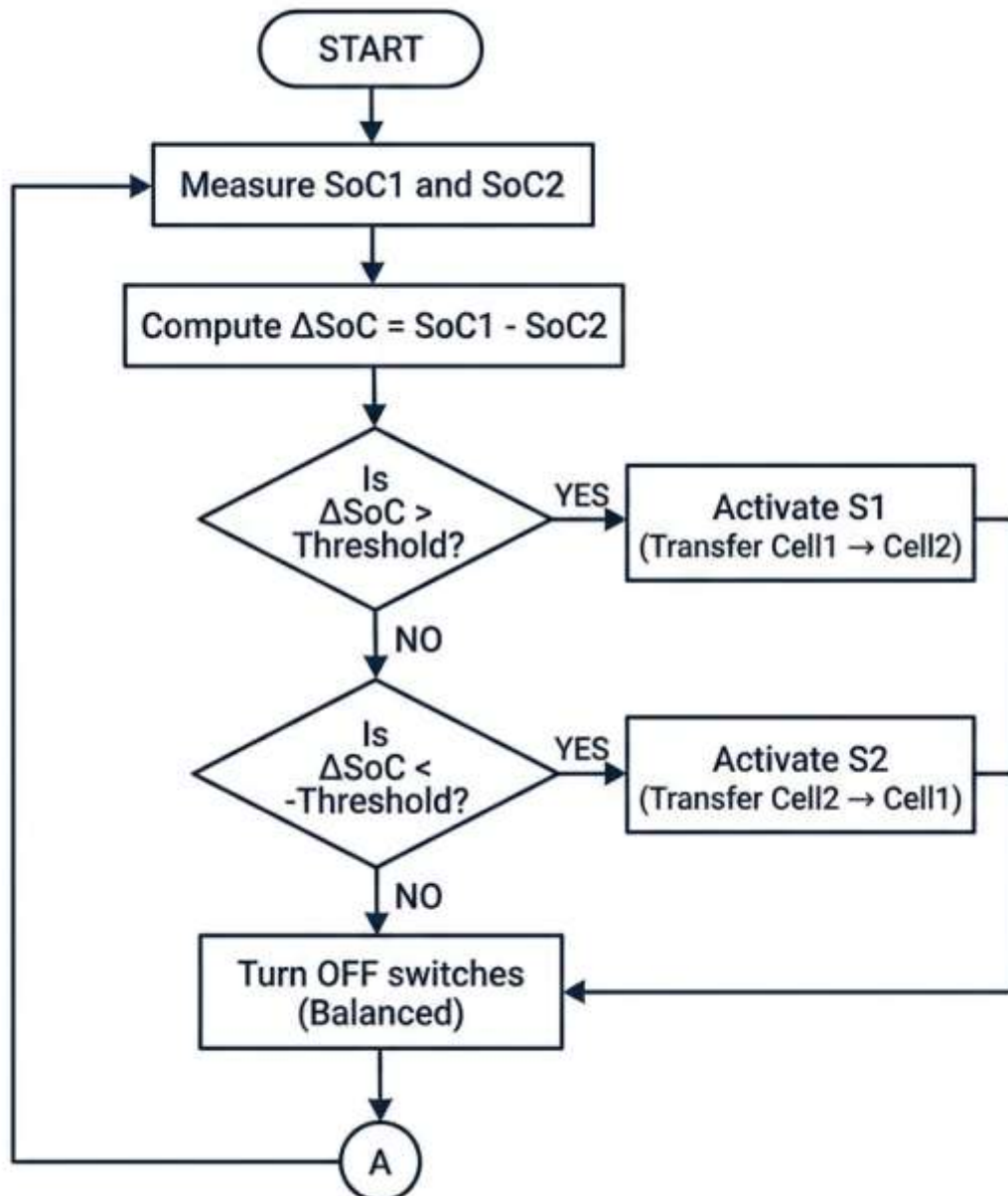

3.7 Key Features of Proposed System

- Bidirectional energy transfer.
- Reduced energy loss compared to passive methods.
- Controlled balancing using PWM.
- Smooth convergence of SoC.
- Simple and effective MATLAB implementation

Section IV - Simulation / Implementation

The proposed active cell balancing system is simulated and verified using MATLAB/Simulink environment. The model is developed to study the efficiency of inductor-based energy transfer between the cells for different initial imbalance conditions.

4.1 Simulation Setup

The simulation consists of:

- Two cells with different initial SoC values.
- Voltage/SoC measurement blocks.
- Control unit (MATLAB function block).
- PWM generator for switching control.
- Inductor-based bidirectional balancing circuit (with switches and diodes).

In order to ensure the stable switching behavior and the accurate dynamic response, the model is run in the discrete mode.

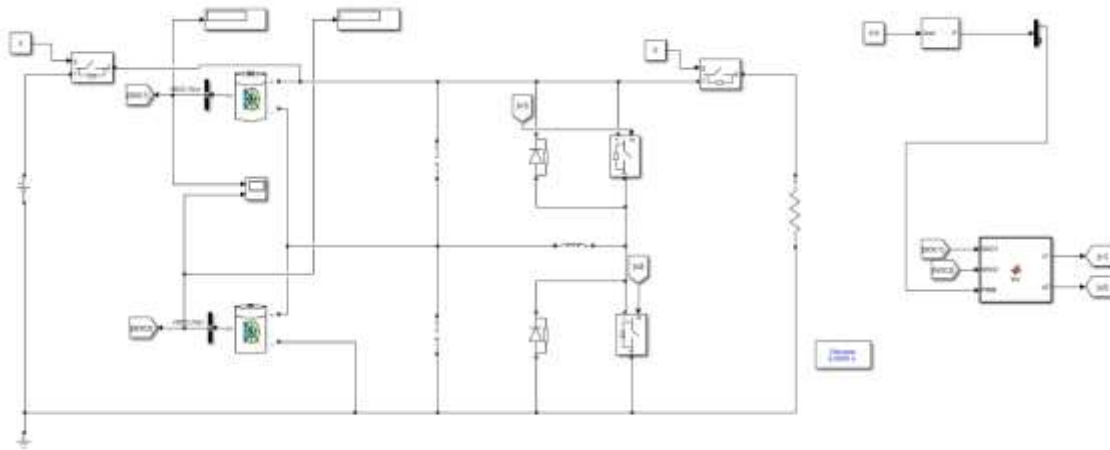

Figure-2 MATLAB/Simulink model of the proposed active cell balancing system.

4.2 Parameters Used

The key parameters considered in the simulation are listed below:

- Cell nominal voltage: 3.6 V – 4.2 V.
- Initial SoC values: Unequal (e.g., 70% and 50%).
- Inductor value (L): Selected for smooth current transfer.
- Switching frequency: High-frequency PWM (kHz range).
- Duty cycle: Controlled based on SoC difference.
- Simulation time: Sufficient to observe convergence.
- Threshold (ϵ): Small value for SoC equalization.

4.3 Model Description

The simulation model operates through the continuous monitoring of SoC of both cells and comparing their values in the control unit. Then, the proper switching signals are generated according to the SoC difference.

The PWM generator creates pulses to drive the switches with energy transfer through the inductor. The transfer of energy from a cell with higher SoC to the cell with lower SoC is achieved via controlled switching.

The inductor serves as an intermediate energy storage element to provide smooth and efficient transfer. The process continues dynamically with feedback until the SoC values of both cells are almost equal.

4.4 Simulation Results (SoC Analysis)

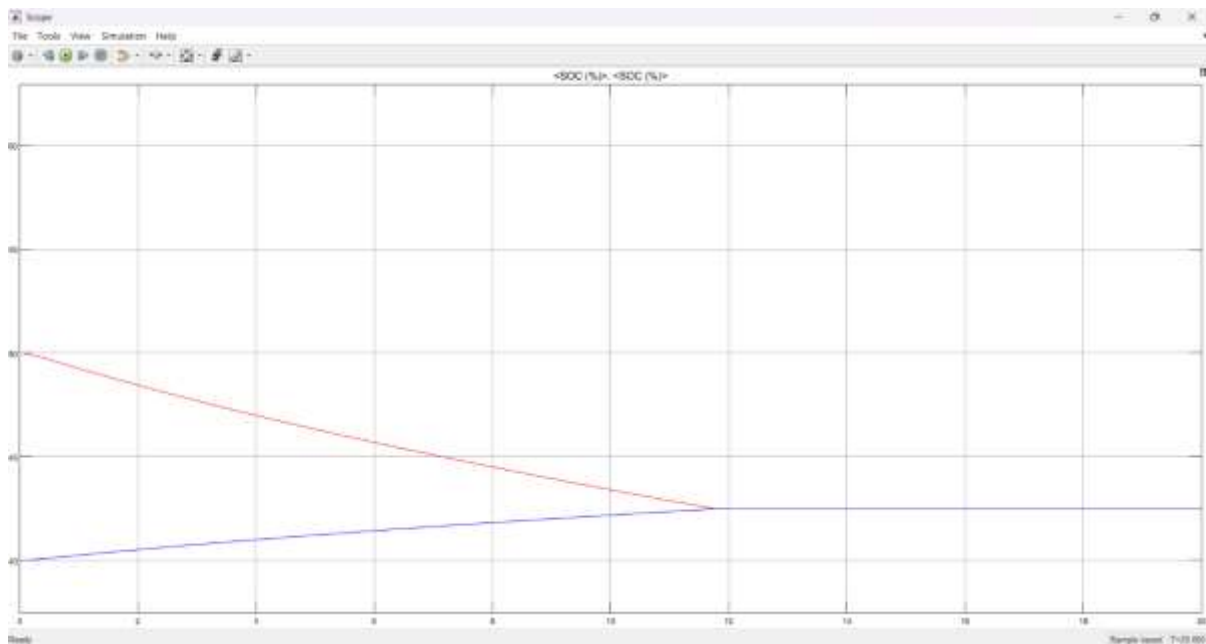

Figure-3 SoC equalization under cell balancing condition.

As depicted in Figure-3, the State of Charge (SoC) variation for two cells when balanced without an outside power source, Cell 1 starts off at an SoC of approximately 50%, and Cell 2 at an SoC of about 40%. There is quite a large difference between these initial SoCs; therefore, these two cells are unbalanced.

As time goes on in the simulation, Cell 1's SoC decreases, and Cell 2's SoC increases. This indicates that energy is being transferred from the cell with the higher SoC to the cell with the lower SoC via the balancing circuit.

The two SoC curves are converging to approximately the same value of 42%, which provides evidence that there has been effective equalization of these two cells' SoC values. Furthermore, the curves demonstrate a smooth and stable convergence with no apparent oscillations, thereby proving the method of balancing proposed in this research is effective and stable.

The SoC versus Time graph is used to evaluate the performance of the proposed system. Initially, there is a large difference in SoC between the cells. As the balancing process proceeds, the SoC values tend to converge progressively.

The results show a clear decay of SoC difference with time, indicating a successful charge redistribution. The convergence is smooth and stable, without any oscillation or sudden

jumps. Eventually both cells reach almost the same SoC values which proves the successful balancing.

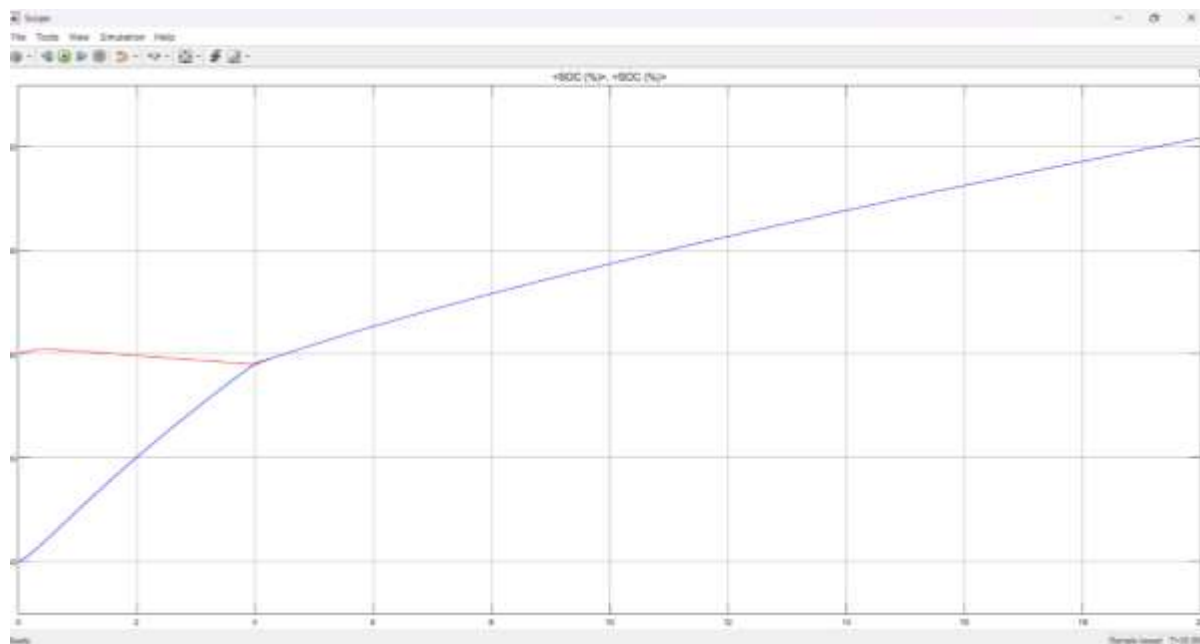

Figure-4 SoC variation under external supply condition.

The external power supply has an effect on how the state of charge is related to the capacitor cells in reference to the last figure and now we see that they are both starting out at unequal states of charge.

In this case, it can be observed that the states of charge are not matching as each capacitor cell continues to receive energy from the external power supply, thus continuing to cause the two capacitor cells to experience different rates of state of charge increase, one cell increasing its state of charge at a higher rate than the second cell, indicating that there continues to be energy being supplied to the overall system which will continue to affect how the two capacitor cells have an even distribution of charge.

In this situation, the charging processes will take precedence over the rate at which the balancing action occurs; therefore the system cannot equalize resulting in the two capacitor cells diverging in state of charge over the time period measured.

As seen in Figure-3 and Figure-4, the suggested system successfully reaches SoC equalization in the absence of any supply current (i.e., with no charge being used for balancing). However, when there is some external supply applied, the system's behavior is no longer purely balanced, and the charge produced during balancing takes priority over the balancing itself.

This shows that, though the charging effect during balancing does not override the mechanism, its effectiveness depends on external operating conditions (such as supply current) at the time of operation.

Section V - Conclusion and Future Work

Conclusion

In this work, we designed and implemented an active cell balancing technique using MATLAB/Simulink to achieve uniform State of Charge (SoC) among cells. The proposed method uses an inductor-based energy transfer system and a control strategy to effectively redistribute charge from cells with higher SoC to those with lower SoC.

Simulation results show that, under balancing conditions, the SoC values of the cells smoothly converge to a common level. This confirms the effectiveness and stability of the proposed approach. The lack of oscillations and the gradual convergence point to controlled and reliable operation.

Further analysis under external supply conditions reveals that the system behavior is influenced by charging dynamics. Here, equalization is affected by the strength of the external energy input. This underscores the importance of operating conditions in shaping balancing performance.

Overall, the proposed method delivers efficient charge redistribution, better use of available energy, and stable operation. The simplicity of the control strategy and the effectiveness of the results make it suitable for further development and real-time implementation.

Future Work

The system can also be extended to the multi cell condition for better scalability. The control strategy can also be improvised by using better algorithms which can make the balancing faster and precise. One is the hardware implementation that is also an option to verify the simulation result with the practical circumstances. The enhancement can also be done dynamically on the optimization of switching control, effect of thermal changes and during charge condition.

References

- G. L. Plett, *Battery Management Systems – Volume I: Battery Modeling*, Artech House, 2015.
- M. Daowd, N. Omar, P. Van Den Bossche, and J. Van Mierlo, “Passive and Active Battery Balancing Comparison Based on MATLAB Simulation,” *IEEE Vehicle Power and Propulsion Conference*, 2011.
- H. Park, C. Kim, K. Kim, and G. Moon, “A Modularized Charge Equalizer for an HEV Lithium-Ion Battery String,” *IEEE Transactions on Industrial Electronics*, 2013.
- J. Kim, J. Shin, C. Chun, and B. Cho, “Stable Configuration of Li-ion Series Battery Pack Based on Active Balancing,” *IEEE Transactions on Power Electronics*, 2017.
- C. Zhang, J. Jiang, W. Zhang, S. Sharkh, and X. Zhang, “An Improved Battery Management System for Electric Vehicles,” *IEEE Transactions on Industrial Electronics*, 2018.