FALCONEYE: TACTICAL SURVEILLANCE & DELIVERY DRONE

K. Rajesh Babu¹, Mr. G. Gnaneshwar Kumar² Rudavath Eshwar³, Mohammad Toufeeq⁴, Sokkam Sampath⁵

^{1,2} Assistant Professor, Department of *ELECTRICAL AND ELECTRONICS ENGINEERING GURU NANAK INSTITUTIONS TECHNICAL CAMPUS*

^{3,4,5} UG Scholars, Department of *ELECTRICAL AND ELECTRONICS ENGINEERING GURU NANAK INSTITUTIONS TECHNICAL CAMPUS*

ABSTRACT: Unmanned Aerial Vehicles (UAVs), commonly referred to as drones, are becoming increasingly significant in various sectors due to their ability to perform tasks that are dangerous, time-consuming, or difficult for humans to handle manually. This project focuses on the design and development of a Surveillance and Light Cargo Carrier Drone that integrates real-time monitoring capabilities with small-scale payload transportation. The system is built on a quadcopter platform powered by brushless DC motors and regulated using electronic speed controllers for stable and efficient flight. A flight controller serves as the core intelligence unit, ensuring balance, stability, and responsiveness to remote control inputs. A wireless FPV/HD camera enables live video transmission, allowing the operator to observe distant or inaccessible areas for security and inspection purposes.

In addition to surveillance, the drone is equipped with a servo-actuated payload carrying mechanism, capable of delivering lightweight items such as medical supplies, emergency kits, or essential goods in areas affected by disasters, conflict, or limited accessibility. The system aims to reduce human risk, lower operational cost, and improve efficiency in field operations such as border monitoring,

search and rescue, agricultural observation, and disaster response. Its modular design allows customization and scalability based on specific use-case requirements. Overall, the proposed drone offers a cost-effective, flexible, and practical aerial solution that combines real-time situational awareness with reliable light- cargo delivery capability.

1. INTRODUCTION

In recent years, drones have evolved from simple hobbyist gadgets into highly capable and intelligent systems that serve a wide range of professional and industrial applications. Initially developed for recreational use and basic aerial photography, modern drones are now equipped with sophisticated technologies that enable them to perform complex tasks with high precision and reliability. Among these advancements, Surveillance and Light Cargo Carrier Drones have gained significant importance in both civil and defense sectors due to their dual functionality and operational flexibility.

A surveillance and light cargo carrier drone is an unmanned aerial vehicle (UAV) specifically designed to perform two key functions: real-time monitoring of designated areas and transportation of small payloads over short to medium distances. These drones combine the

capabilities of aerial surveillance systems with efficient logistics support, making them highly valuable in situations where rapid response and accessibility are critical. Their compact design, autonomous navigation, and ease of deployment make them suitable for both urban and remote environments.

Equipped with advanced sensors, high-definition cameras, thermal imaging systems, and GPS-based navigation, these drones provide accurate and real-time aerial intelligence. They are widely used for applications such as border surveillance, disaster management, traffic monitoring, environmental observation, and security patrolling. In defence scenarios, they assist in reconnaissance missions and threat detection, while in civil applications, they enhance public safety and infrastructure monitoring. Their ability to capture live video feeds and transmit data instantly to control stations significantly improves decision-making and situational awareness.

In addition to surveillance, their cargo-carrying capability enables them to transport lightweight materials such as medical supplies, emergency equipment, food packages, and essential goods. This is particularly useful in disaster-stricken areas, remote villages, mountainous terrains, and regions with limited transportation infrastructure. By reducing dependency on conventional transportation methods, these drones ensure faster and more efficient delivery, especially during emergencies where time is a critical factor.

The integration of surveillance and cargo delivery into a single platform enhances overall operational efficiency and reduces the need for multiple systems. It minimizes

manpower requirements, lowers operational costs, and enables quick deployment in urgent situations. Furthermore, advancements in battery technology have improved flight endurance, while modern flight control systems ensure stability, accuracy, and safety during operations. The incorporation of artificial intelligence and machine learning algorithms allows for autonomous navigation, obstacle avoidance, and intelligent decision-making.

Overall, surveillance and light cargo carrier drones represent a modern, sustainable, and versatile technological solution. Their ability to perform multiple functions simultaneously makes them highly effective across various sectors, including defence, healthcare, logistics, agriculture, and disaster management. As technology continues to evolve, these drones are expected to become even more efficient, reliable, and widely adopted, playing a crucial role in shaping the future of aerial operations and smart logistics systems.

2. Proposed System:

The proposed system introduces a multifunctional drone designed to perform both real-time aerial surveillance and light cargo transportation in a single integrated platform. This system aims to overcome the limitations of traditional methods by combining monitoring and delivery capabilities, thereby improving efficiency, flexibility, and operational effectiveness. The drone is engineered to operate in diverse environments, including urban areas, remote locations, and disaster-affected regions, making it a versatile solution for multiple applications.

The drone integrates a high-definition camera module capable of capturing and transmitting live video footage to a ground control station. This enables operators to monitor specific areas remotely with enhanced accuracy, situational awareness, and real-time decision-making capability. The inclusion of features such as adjustable camera angles, wireless transmission, and potential night-vision or thermal imaging support further enhances its surveillance performance. This real-time monitoring capability is particularly beneficial in applications such as border security, disaster assessment, traffic monitoring, and industrial inspections.

In addition to surveillance, the system incorporates a lightweight payload carrying mechanism that allows the drone to transport and deliver essential items efficiently. The payload system is designed to carry small but critical materials such as medical supplies, emergency kits, food packets, and important documents. A controlled release mechanism ensures accurate and safe delivery of the payload at the target location. This feature is especially useful in emergency situations where immediate delivery is required in areas that are otherwise inaccessible due to terrain, infrastructure damage, or safety concerns.

The drone is powered by high-efficiency brushless DC motors, which provide greater thrust, durability, and energy efficiency compared to conventional motors. These motors are coupled with electronic speed controllers (ESCs) to ensure precise control of motor speed and stable flight performance. A reliable flight controller unit processes sensor data and maintains balance, orientation, and

navigation of the drone. With the help of onboard sensors such as gyroscopes, accelerometers, and GPS modules, the drone achieves stable maneuvering, accurate positioning, and autonomous flight capabilities.

Furthermore, the system is designed with user-friendly controls, allowing operators to manage both surveillance and delivery functions with minimal training. The integration of wireless communication technologies ensures seamless transmission of control signals and data between the drone and the operator. Advanced features such as obstacle avoidance, waypoint navigation, and return-to-home functionality can also be incorporated to enhance safety and automation.

By reducing the need for direct human involvement in risky environments, the proposed system significantly minimizes safety risks. It also lowers operational costs by replacing multiple systems with a single integrated solution. The rapid deployment capability of the drone improves response time during emergencies, enabling quicker assessment and action. Additionally, its ability to access difficult terrains such as mountains, flood-affected areas, and disaster zones ensures better reach and effectiveness.

Overall, this proposed system provides a cost-effective, efficient, and reliable solution for modern surveillance and logistics challenges. Its dual functionality, combined with advanced control and sensing technologies, makes it highly suitable for applications in disaster management, defense monitoring, healthcare delivery, and general field inspections, thereby contributing to

improved safety, efficiency, and technological advancement.

2.1 Block diagram

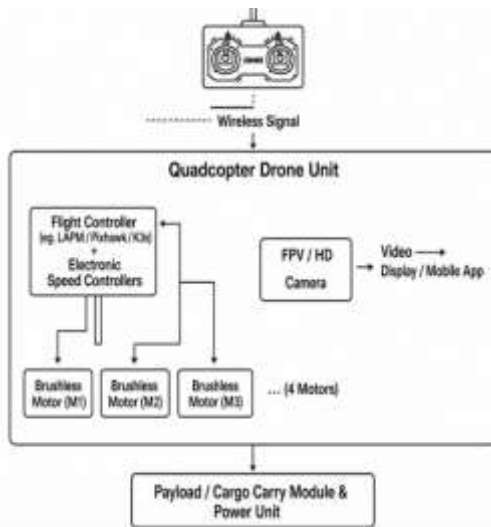

Fig. 1: Proposed system Block diagram

3. Modules Description

A. Brushless DC Motors (BLDC)

Brushless DC motors are the primary propulsion units of the drone. They convert electrical energy into mechanical energy to rotate the propellers and generate thrust. BLDC motors operate without brushes, resulting in high efficiency, reduced maintenance, and longer operational life. Their quick response and high power-to-weight ratio enable stable and precise flight control.

B. Electronic Speed Controller (ESC)

The Electronic Speed Controller regulates the speed of the BLDC motors by controlling the power supplied to them. It receives input signals from the flight controller and adjusts motor speed accordingly. ESCs allow smooth acceleration, deceleration, and precise

control of motor rotation, ensuring stability and maneuverability during flight.

C. Propellers

Propellers are responsible for generating lift and thrust by converting rotational motion into aerodynamic force. The drone typically uses a combination of clockwise and counterclockwise rotating propellers to maintain balance. The design, size, and pitch of the propellers significantly influence flight efficiency and performance.

D. Battery

The battery acts as the primary power source for the drone. Lithium-Polymer (Li-Po) batteries are commonly used due to their lightweight and high energy density. The battery supplies power to all components, including motors, ESCs, and onboard electronics. Battery capacity directly affects flight time and payload capability.

E. Camera

The camera module is used for real-time surveillance and monitoring. It captures aerial images and videos, which are transmitted to a ground station. Advanced camera systems may include stabilization and high-definition recording features, enabling effective observation and data collection.

F. Transmitter and Receiver

The transmitter and receiver establish wireless communication between the drone and the operator. The transmitter sends control signals, while the receiver

interprets them and forwards them to the flight controller. This system ensures real-time control and accurate maneuvering of the drone.

4. REVIEW OF LITERATURE

The Surveillance and Light Cargo Carrier Drone is a multi-purpose unmanned aerial vehicle (UAV) designed to perform both aerial monitoring and lightweight cargo delivery within a single integrated platform. This project focuses on developing a smart and efficient drone system that can address modern challenges in surveillance and logistics, especially in areas where traditional methods are ineffective or risky. By combining monitoring and delivery functionalities, the system enhances operational capability while reducing the need for multiple separate systems.

The main objective of this project is to create a cost-effective, efficient, and semi-autonomous drone system capable of providing real-time surveillance data while also transporting small payloads to remote or inaccessible locations. The system is designed with an emphasis on reliability, ease of use, and adaptability across different applications such as disaster management, defense operations, agricultural monitoring, and industrial inspection. It aims to minimize human intervention in hazardous environments while improving the speed and accuracy of operations.

The drone integrates a high-resolution camera module that enables continuous aerial monitoring and live video streaming. This allows operators to observe real-time conditions from a remote ground control station, improving situational awareness

and decision-making. The inclusion of GPS-based navigation enables the drone to track its position accurately, follow predefined flight paths, and perform waypoint-based missions. Wireless communication systems ensure uninterrupted transmission of video and telemetry data between the drone and the operator, making the system highly responsive and reliable.

The drone is capable of performing various flight operations such as hovering at a fixed location, autonomous navigation along predefined routes, and returning to its starting point after completing a mission. These capabilities are essential for applications like border surveillance, search-and-rescue missions, and environmental monitoring. The real-time data transmission feature allows authorities to take immediate action based on live information, thereby improving operational efficiency and safety.

In addition to surveillance, the drone is equipped with a dedicated cargo module designed to carry lightweight materials such as medical supplies, emergency kits, documents, and small spare parts. The payload delivery system is engineered to ensure secure transportation and controlled release of materials at the desired location. This feature makes the drone highly useful for emergency deliveries, particularly in disaster-affected areas, remote villages, or locations with poor infrastructure where conventional transportation methods are not feasible.

The drone operates using high-performance brushless DC (BLDC) motors, which provide efficient thrust, longer lifespan, and reduced maintenance compared to conventional motors. A

central flight controller acts as the brain of the system, processing input from sensors and maintaining flight stability. Rechargeable lithium-polymer (Li-Po) batteries are used as the primary power source, offering high energy density and sufficient flight endurance for extended operations.

To further enhance stability and safety, the drone is equipped with multiple sensors such as gyroscopes and accelerometers, which help maintain balance and orientation during flight. Ultrasonic sensors or similar proximity sensors are used for obstacle detection and avoidance, ensuring safe navigation even in complex environments. These sensors enable the drone to make real-time adjustments, improving its reliability and performance.

Overall, the Surveillance and Light Cargo Carrier Drone represents an innovative and practical solution that integrates modern technologies to meet current surveillance and logistics needs. Its ability to perform dual functions, combined with autonomous features and advanced sensing capabilities, makes it a valuable tool for various sectors. The system not only improves operational efficiency and reduces risks but also contributes to the advancement of smart and sustainable aerial technologies.

5. METHODOLOGY:

- **Problem Identification**

Identify the need for a dual-purpose drone that can perform both surveillance and light cargo delivery.

- **Component Selection**

Choose suitable hardware such as frame, BLDC motors, ESCs, camera

module, Li-Po battery, flight controller, transmitter/receiver, and payload mechanism.

- **System Design**

Create the structural layout, wiring diagram, and block diagram to integrate propulsion, control, camera, and payload systems.

- **Assembly & Integration**

Mount all components on the frame, connect electronics through the PDB, configure ESCs, and calibrate sensors.

- **Software Configuration**

Install and tune flight controller firmware (Ardu Pilot/Betaflight), set up GPS, and configure radio communication.

- **Testing & Calibration**

Perform motor testing, PID tuning, hover tests, payload mechanism testing, and camera transmission checks.

- **Performance Evaluation**

Evaluate flight stability, endurance, video quality, and payload accuracy under different conditions.

- **Documentation & Refinement**

Record results, make improvements, and finalize the prototype.

6. Working Principle

The Surveillance and Light Cargo Carrier Drone operates based on the fundamental principles of aerodynamics, propulsion, control systems, and wireless communication. These principles work together to enable the drone to achieve stable flight, precise navigation, and

efficient task execution. The aerodynamic design of the drone frame, combined with high-speed rotating propellers, generates the necessary lift force to overcome gravity and allow vertical takeoff. By varying the speed of individual motors, the drone can control its motion in all directions, including upward, downward, forward, backward, and lateral movements.

The propulsion system consists of brushless DC (BLDC) motors and propellers, which are responsible for generating thrust. These motors are highly efficient, reliable, and capable of providing the required power for sustained flight. Each motor is connected to an Electronic Speed Controller (ESC), which regulates the speed of the motor by adjusting the electrical signals based on commands received from the flight controller. By precisely controlling the speed of each motor, the drone maintains balance and performs controlled maneuvers such as hovering, turning, and altitude adjustment.

At the core of the system is the flight controller, which acts as the central processing unit or “brain” of the drone. It continuously receives and processes data from various onboard sensors, including the gyroscope, accelerometer, and barometer. The gyroscope measures angular velocity and helps maintain orientation, while the accelerometer detects linear motion and tilt. The barometer is used to estimate altitude by measuring air pressure. Based on this sensor data, the flight controller makes real-time adjustments to motor speeds to ensure stability, balance, and smooth flight performance, even in the presence of disturbances such as wind.

The power system of the drone is designed to ensure efficient energy distribution and reliable operation. A rechargeable lithium-polymer (Li-Po) battery serves as the primary power source, providing high energy density and lightweight characteristics. The Power Distribution Board (PDB) distributes electrical power from the battery to all essential components, including the ESCs, flight controller, sensors, and communication modules. Proper power management is crucial for maintaining consistent performance and extending flight duration.

For surveillance functionality, the drone is equipped with a high-definition camera that captures real-time aerial images and video. This data is transmitted wirelessly to a ground control station using radio frequency or Wi-Fi-based communication systems. The operator can monitor live footage, analyze the environment, and make informed decisions during operations such as security monitoring, disaster assessment, or environmental observation.

In addition to surveillance, the drone includes a payload delivery mechanism designed for transporting lightweight materials. This mechanism typically uses a servo motor to control the release of the payload. The operator can remotely activate the servo to drop items such as medical kits, documents, or emergency supplies at the desired location. This feature enhances the drone’s usefulness in emergency situations and remote area logistics.

Communication between the drone and the operator is established through a transmitter and receiver system, which enables real-time control and feedback. The operator sends control commands via

the transmitter, while the receiver onboard the drone relays these signals to the flight controller. At the same time, telemetry data such as battery status, altitude, speed, and position can be sent back to the operator, ensuring better control and monitoring of the drone's performance.

Overall, the drone functions through the coordinated interaction of its propulsion system, control unit, sensor network, power distribution system, and communication modules. This integration allows the drone to perform complex tasks efficiently, including stable flight, real-time surveillance, and precise cargo delivery. The combination of these technologies makes the system highly effective, reliable, and suitable for modern applications in security, disaster management, and logistics.

7. System design

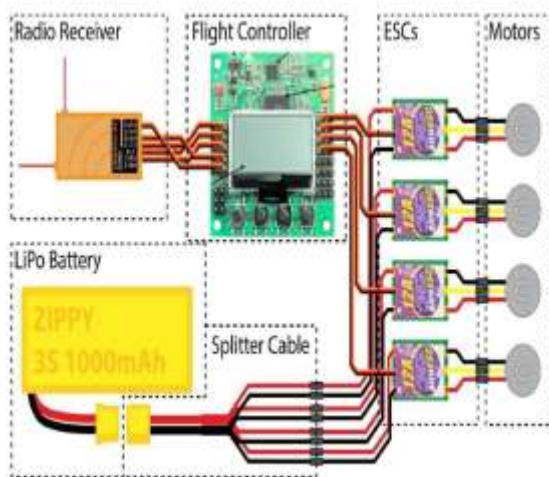

Fig.2:design

8. Implementation And Final Output Results



Final output results



9. CONCLUSION

The Surveillance and Light Cargo Carrier Drone effectively combines aerial monitoring and lightweight delivery in one system. Using stable propulsion, a reliable flight controller, and an onboard camera with a payload mechanism, the drone performs its tasks efficiently. This project shows how UAVs can support security, emergency response, and short-distance logistics with a low-cost, flexible design.

REFERENCES

1. Ardu Pilot Documentation – <https://ardupilot.org/>

2. PX4 Autopilot Guide – <https://px4.io/>
3. DJI Research Papers on UAV Surveillance
4. “Unmanned Aerial Vehicles: Applications and Technologies,” IEEE Journals
5. “Design and Control of Quadrotor UAVs,” International Journal of Advanced Robotics
6. BLDC Motor and ESC datasheets
7. Li-Po Battery Safety and Handling Guides