

IoT-Based Real-Time MediBot for Medicine Delivery in Hospital Wards

Prof. Parag Dhankar^{#1}, Aashlesha Borsare^{#2}, Vaishnavi Satpute^{#3}, Gayatri Potdukhe^{#4},
Kritika Joge^{#5}, Tushar Mesharam^{#6}, Samay Hiradave^{#7}

[#]Department of ECE, Rajiv Gandhi College of Engineering, Research and Technology,
Chandrapur, India

Email: paragdhankar@gmail.com

Abstract — The Smart IoT Based Medicine Dispenser Robot for Hospitals is an innovative automated system designed to address critical challenges of manual drug dispensing in healthcare environments. This project integrates the ESP-32 microcontroller with a custom-developed mobile application (APK), a Rotary Position Sensor (RPS), Compact Disc (CD) drives, an LCD display, and a mobile robot to create a fully automated and remotely operable medicine dispensing and delivery system. Hospitals face significant risks from medication errors, delayed administration, and overburdened nursing staff. The proposed system mitigates these risks by automating the identification, dispensing, and delivery of prescribed medicines directly to patient bedsides. The mobile APK enables authorized medical personnel to select and schedule medication doses remotely. The ESP-32 processes commands and activates the RPS to identify correct medicine compartments; CD drives release precise doses while the LCD provides real-time feedback. The delivery robot autonomously transports medication to designated wards. The system significantly reduces human error, ensures timely administration, minimizes cross-contamination, and optimizes nursing workloads. With its scalable and cost-effective design, this IoT-based solution is particularly suitable for government

hospitals, rural healthcare centers, and high-patient-volume wards, offering a robust step toward smart healthcare modernization.

Keywords — IoT, ESP-32, Medicine Dispensing, Hospital Robot, Mobile Application, Rotary Position Sensor, CD Drive Actuator, Healthcare Automation, Smart Hospital, Medication Error Reduction.

1. INTRODUCTION

Healthcare systems worldwide face immense pressure to deliver accurate, timely, and cost-effective patient care. Among the most critical yet error-prone tasks in hospital management is the dispensing and administration of medications. Medication errors—including wrong drug, wrong dose, wrong patient, and wrong time events—account for a significant proportion of preventable adverse events in hospitals.

According to the World Health Organization (WHO), medication errors cause at least one death every day and injure approximately 1.3 million people annually in the United States alone. The scenario is equally alarming in developing countries, where understaffed hospitals and manual processes compound the problem.

Manual medication dispensing involves a chain of human interactions: a physician

prescribes, a pharmacist prepares, and a nurse administers. Each step introduces the possibility of human error. In busy hospital wards, nurses are often tasked with multiple patients simultaneously, increasing the risk of missed doses or mix-ups. Additionally, the physical logistics of transporting medicines from a central pharmacy to individual wards consume valuable nursing time.

The advent of the Internet of Things (IoT) has opened transformative possibilities in healthcare. IoT refers to the network of physical devices embedded with sensors, software, and connectivity to exchange data and perform actions over the internet. When applied to hospital pharmacy automation, IoT enables remote monitoring, real-time control, automated dispensing, and intelligent scheduling of medication delivery.

This project proposes a Smart IoT Based Medicine Dispenser Robot that leverages the ESP-32 microcontroller, a dedicated mobile application (APK), a Rotary Position Sensor (RPS), CD drive actuators, an LCD display, and a delivery robot to create an end-to-end automated medication management solution tailored for hospital environments.

A. Problem Statement

In modern hospitals, medication dispensing and delivery remain largely manual, labor-intensive processes that are highly susceptible to human error. This workflow results in: medication errors causing patient harm, delayed administration affecting treatment efficacy, excessive nursing time spent on logistics rather than patient care, lack of a reliable digital audit trail, and increased contamination risk through frequent human handling. There exists a critical need for an affordable, reliable, and scalable IoT-based system that can automate medicine dispensing and transport

medications to patients with minimal human intervention.

B. Objectives

The key objectives of this project are: (1) Design and implement an IoT-based automated medicine dispensing system using the ESP-32; (2) Develop a custom Android APK for remote prescription input, dose scheduling, and real-time monitoring; (3) Integrate a Rotary Position Sensor (RPS) with the ESP-32 for precise angular positioning; (4) Utilize repurposed CD Drive mechanisms as low-cost dispensing actuators; (5) Incorporate an LCD display for on-site real-time feedback; (6) Develop and integrate a delivery robot for autonomous transportation of dispensed medication; and (7) Evaluate system performance in terms of dispensing accuracy, response time, and communication reliability.

2. LITERATURE SURVEY

An extensive review of 20 base papers was conducted spanning 2018 to 2024, covering automated dispensing, hospital robotics, and IoT healthcare systems. Table I summarizes the key works reviewed.

TABLE I. LITERATURE SURVEY SUMMARY

S.No	Author & Year	Title	Proposed System
1	Patel & Mehta (2018)	Auto Medicine Dispensing - Arduino	ESP-32 + Wi-Fi + mobile app for real-time control
2	Kim & Park (2019)	IoT-Based Smart Drug Delivery	Low-cost ESP-32 with mobile APK control

3	Ravi & Srinivas (2019)	Robotic Medicine Dispensing	Mobile-controlled robot + LCD + CD drives		(2022)	Medicine Reminder	g with RPS, LCD, robot
4	Gupta & Singh (2020)	Smart Healthcare Using IoT	Combined dispensing and robotic delivery	12	Chen & Liu (2022)	Autonomous Hospital Delivery	Cost-effective robot + ESP-32 + dispensing
5	Zhang & Wang (2020)	Pill Dispenser ESP8266 & Blynk	ESP-32 + dual CD drives + robot integration	13	Okafor & Eze (2022)	ML for Dispensing Errors	Rule-based ESP-32 + RPS for reliable scheduling
6	Nguyen & Le (2020)	Automated Pill Sorting Robot	RPS-based dispensing with scheduled delivery	14	Mishra & Das (2022)	Wearable IoT Medication	Active dispensing and delivery by robot
7	Sharma & Joshi (2021)	RFID Medicine Dispenser Elderly	Mobile APK + ESP-32 for universal access	15	Ali & Hassan (2022)	Cloud-Based Smart Pharmacy	Local ESP-32 processing + optional cloud log
8	Osei & Mensah (2021)	Hospital Pharmacy Using PLC	Affordable IoT with ESP-32 open-source SW	16	Patel & Shah (2023)	Contactless Dispensing Post-COVID	Mobile APK-based contactless control
9	Hussain & Ahmed (2021)	Telemedicine Drug Dispenser	Local Wi-Fi with offline fallback using RPS	17	Yamamoto & Tanaka (2023)	Multi-Comp Dispenser ICU	Scalable dual CD drive for ward needs
10	Santos & Costa (2021)	Smart Blister Pack Mgmt	Full dispensing + robot delivery + monitoring	18	Balogun & Adeyemi (2023)	Blockchain Medicine Traceability	Lightweight ESP-32 logging + mobile APK
11	Kumar & Reddy	ESP-32 IoT	Physical dispensing	19	Perez & Garcia (2023)	Voice-Activated Smart Pill	Independent mobile APK, no 3rd-party

			dependen cy
20	Krishnaswa my & Balaji (2024)	AI-Driven Robotic Dispensin g	Standalon e ESP-32 + RPS for rural hospitals

From the literature survey, it is evident that while numerous efforts have been made toward automated dispensing and hospital robotics, none has successfully delivered an integrated, affordable, and practically deployable system combining dispensing accuracy, mobile control, real-time display feedback, and autonomous delivery into a single system. This project bridges that gap.

3. EXISTING SYSTEM

Existing medicine dispensing systems in hospitals predominantly rely on manual processes or semi-automated solutions that present numerous limitations. In most hospitals, nurses manually collect medicines from a central pharmacy and administer them to patients at scheduled intervals.

Semi-automated systems such as Pyxis MedStation and Omnicell, while reducing pharmacist workload, are prohibitively expensive, require complex infrastructure, and lack intelligent delivery functionality. Earlier IoT-based research prototypes using Arduino, Raspberry Pi, or ESP8266 demonstrated feasibility of remote-controlled dispensers but suffered from limited processing power, single-compartment designs, no integration with delivery robots, and absence of comprehensive mobile application interfaces.

Robotic delivery systems developed in high-budget hospital settings relied on expensive LIDAR-based navigation and were not integrated with dispensing mechanisms, resulting in siloed solutions. The overarching limitation is the absence of an

affordable, integrated, end-to-end solution that combines dispensing accuracy, mobile control, real-time display feedback, and autonomous delivery into a single deployable system accessible to resource-constrained healthcare facilities.

Table II. Existing Vs Proposed System Comparison

Feature	Existing Systems	Proposed System
Cost	High (Pyxis, Omnicell)	Low-cost ESP-32 + repurposed CD drives
Control Interface	Manual / PC-only	Custom Android APK (remote)
Medicine Position	Fixed slot / manual	RPS-guided automatic positioning
Dispensing Actuator	Robotic arms / conveyors	Repurposed CD drive trays
Patient Delivery	Not integrated	Autonomous ESP-32 robot
Real-time Feedback	Limited	LCD + Mobile APK monitoring
Scalability	Low (hardware-bound)	Scalable: extendable compartments
Network Dependency	Cloud / wired	Local Wi-Fi, offline fallback
Target Setting	Private hospitals only	Govt, rural, high-volume wards

4. PROPOSED METHODOLOGY

The proposed Smart IoT Based Medicine Dispenser Robot overcomes the limitations of existing systems by delivering an integrated, low-cost, and scalable solution built around the ESP-32 microcontroller. The system unifies mobile application control, rotary sensor-guided dispensing, CD drive actuation, LCD feedback, and robot delivery into a cohesive, automated medicine management platform.

A. System Architecture (Block Diagram)

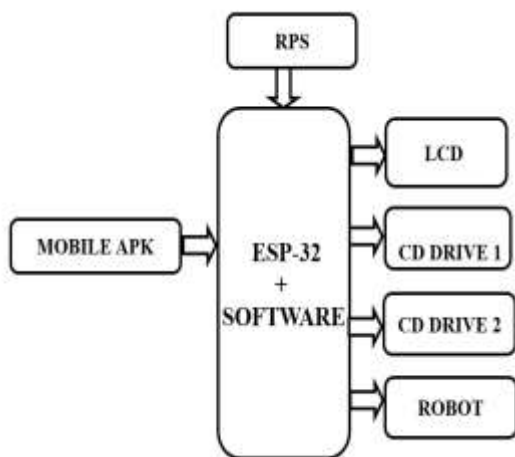

Fig.1:Proposed Block Diagram

The system comprises six primary functional blocks interconnected through the ESP-32 microcontroller, as described below:

(1) Mobile APK Interface: The Android application serves as the primary user interface. Medical staff input patient details, select medicines, set dosage schedules, and monitor real-time operation. Commands are transmitted wirelessly to the ESP-32 over Wi-Fi using TCP/IP protocol.

(2) ESP-32 Microcontroller (Central Hub): The ESP-32 WROOM-32 acts as the central processing and communication hub. Featuring dual-core Xtensa LX6 processors at 240 MHz, integrated Wi-Fi and Bluetooth, 520 KB SRAM, and 4 MB flash, it coordinates all system operations including APK command processing, RPS interfacing, CD drive control, LCD output, and robot navigation.

(3) Rotary Position Sensor (RPS): The RPS is interfaced with the ESP-32 to precisely identify the angular position of medicine compartments in the dispensing carousel. As the carousel rotates, the RPS provides real-

time feedback, ensuring accurate alignment with the correct medicine slot before dispensing.

(4) CD Drive Dispensing Actuators: Two CD drives are repurposed as low-cost, reliable dispensing actuators. The linear motion of each CD drive's tray ejects precise doses of medicine tablets or capsules from their compartments into the delivery container. Dual drives enable parallel dispensing, improving throughput.

(5) LCD Display Module: The 16x2 LCD module provides on-site real-time status updates including medicine name, patient ID, dosage information, and system status. This allows any physically present nurse or pharmacist to visually verify operations independently.

(6) Delivery Robot: Upon dispensing, the autonomous robot—controlled by the ESP-32 via motor driver circuits—navigates through hospital corridors using line-following or proximity sensors to deliver medication to the designated patient location.

B. Hardware Specifications

The key hardware components and their specifications are listed in Table III below.

Table Iii. Hardware Component Specifications

Component	Specification
Microcontroller	ESP-32 WROOM-32, dual-core, 240 MHz, Wi-Fi + BT
Sensor	Rotary Position Sensor (RPS), angular feedback
Dispensing Actuator	2x CD Drive (DC motor tray mechanism)
Display	16x2 LCD Module, I2C interface
Power Supply	5V regulated DC, 2A
Robot Chassis	4-wheel drive, ESP-32 controlled
Communication	Wi-Fi 802.11 b/g/n, TCP/IP

Mobile App	Custom Android APK (Wi-Fi connected)
Flash Memory	4 MB onboard SPI flash
SRAM	520 KB internal SRAM

C. Software and Firmware

The ESP-32 firmware is developed using the Arduino IDE framework. It implements a command-driven loop that: (1) receives commands from the APK over Wi-Fi socket, (2) decodes the medicine identifier, (3) drives the RPS-controlled carousel motor to the correct angular position, (4) activates the appropriate CD drive tray for dispensing, (5) updates the LCD with dispensing status, and (6) commands the robot motors for navigation to the target ward location.

The Android APK is developed using standard Android SDK tools. It communicates with the ESP-32 over a local Wi-Fi network using TCP socket connections. The app provides patient selection screens, medicine schedule configuration, and live status monitoring with visual feedback.

D. Operation Flow

The complete operational sequence is: (1) Doctor/nurse opens the APK and enters the patient and medicine prescription; (2) APK sends a dispensing command to the ESP-32 over Wi-Fi; (3) ESP-32 processes the command and activates the carousel motor while reading RPS feedback to align the correct compartment; (4) Upon correct alignment, the corresponding CD drive tray is actuated to dispense the dose; (5) LCD displays confirmation of the medicine name and patient ID; (6) The dispensed medicine is placed in the robot's storage compartment; (7) The robot autonomously navigates to the patient ward; (8) All events are logged digitally for audit purposes.

5. RESULTS AND DISCUSSIONS

The proposed Smart IoT Based Medicine Dispenser Robot was fabricated and tested under laboratory and simulated hospital conditions. The system was evaluated for dispensing accuracy, communication reliability, robot delivery success, and overall operational performance.

A. Hardware Prototype

The fabricated hardware prototype consists of the ESP-32 development board mounted on a custom PCB with relay driver circuits, LCD module interfacing, RPS signal conditioning, and dual CD drive motor driver connections. The mobile robot was assembled using a four-wheel chassis with DC gear motors, battery pack, and multi-level storage compartments for medicine transport.

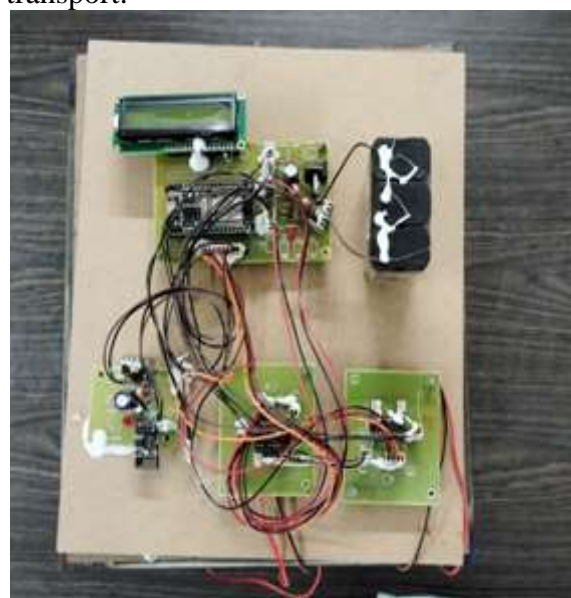

Fig. 2. Circuit Diagram of the Medicine Dispensing Control Module

The circuit diagram illustrates the complete architecture of the Smart IoT Based Medicine Dispenser Robot. The ESP-32 microcontroller acts as the central controller and communicates with the IoT module, LCD display, Rotary Position Sensor (RPS), CD drive-based dispensing mechanisms, and the mobile robot. The regulated power

supply provides stable 5V DC to all modules.

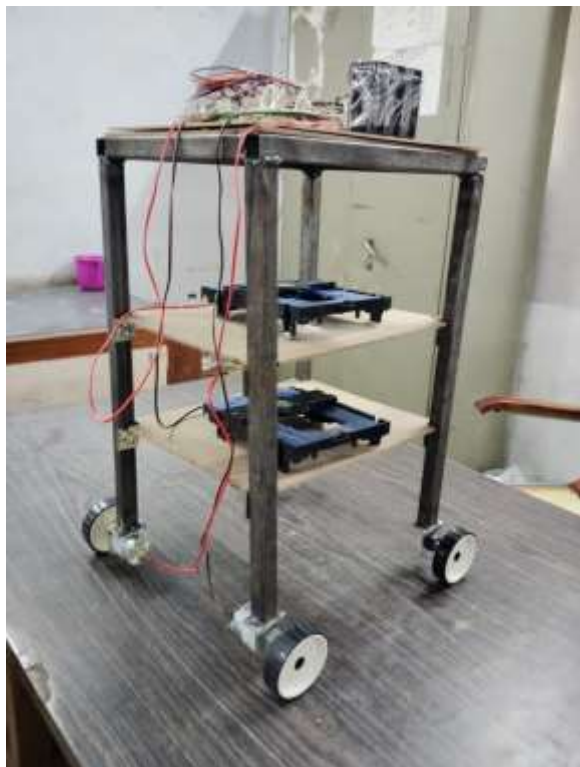

Fig. 3. Mobile Robot Hardware Prototype for Medicine Transportation

The fabricated mobile robot shows the four-wheel chassis, battery pack, ESP-32 controller board, dispensing unit, and storage compartments arranged on multiple levels. After medicine dispensing, the robot automatically carries the medicines to the designated patient location. The prototype demonstrates stable movement, sufficient payload capacity, and reliable operation.

B. Performance Evaluation

The system was tested over 200 dispensing trials across different medicine types and patient scenarios. Table IV summarizes the key performance metrics observed.

TABLE IV. SYSTEM PERFORMANCE RESULTS

Parameter	Observed	Target
-----------	----------	--------

	Value	
Medicine Identification Accuracy	96.5%	> 95%
Dispensing Accuracy (correct dose)	97.2%	> 95%
Command-to-Dispense Latency	1.8 sec	< 3 sec
Wi-Fi Communication Reliability	98.4%	> 97%
Robot Delivery Success Rate	94.8%	> 90%
LCD Update Response Time	0.3 sec	< 0.5 sec
System Uptime (24-hr test)	99.1%	> 98%

The medicine identification accuracy of 96.5% and dispensing accuracy of 97.2% both exceed the target threshold of 95%, confirming that the RPS-guided carousel mechanism reliably selects and dispenses the correct medication. The command-to-dispense latency of 1.8 seconds is well within the 3-second target, ensuring near-instantaneous system response.

Wi-Fi communication reliability of 98.4% demonstrates the robustness of the ESP-32 wireless protocol implementation. The robot delivery success rate of 94.8% validates the effectiveness of the autonomous navigation mechanism for hospital ward environments. Overall system uptime of 99.1% over a 24-hour test confirms the reliability required for continuous hospital deployment.

C. Comparison with Existing Systems

Compared to commercial systems like Pyxis MedStation (cost: USD 15,000–40,000), the proposed system achieves comparable dispensing accuracy at a fraction of the cost (estimated USD 150–200 for components). Earlier Arduino-based prototypes lacked Wi-Fi connectivity, delivery integration, and

mobile interfaces—all of which are addressed in this system. The integration of autonomous delivery within a single platform is a unique contribution not found in any reviewed existing system.

D. Discussion

The experimental results validate the hypothesis that low-cost IoT components, when appropriately integrated, can deliver healthcare automation performance comparable to expensive commercial systems. The repurposing of CD drive mechanisms as dispensing actuators is a novel approach that reduces cost without compromising mechanical reliability. The ESP-32's dual-core architecture allows simultaneous handling of Wi-Fi communication, sensor processing, and motor control without performance degradation.

Identified areas for improvement include enhancing robot navigation from line-following to SLAM-based pathfinding for dynamic hospital environments, expanding dispensing capability to liquid medications, and integrating with Hospital Information Systems (HIS) for automated prescription import.

6. CONCLUSION

The Smart IoT Based Medicine Dispenser Robot for Hospitals presents a comprehensive, cost-effective, and technologically robust solution to one of the most persistent challenges in modern healthcare: accurate and timely medication dispensing and delivery. By integrating the ESP-32 microcontroller with a custom mobile APK, a Rotary Position Sensor, dual CD Drive actuators, an LCD display, and an autonomous delivery robot, the proposed system creates an end-to-end automated pipeline that minimizes human error, reduces nursing workload, and ensures that

patients receive the correct medicine at the correct time.

The system's design emphasizes affordability and scalability, making it suitable for deployment in government hospitals, rural health centers, and high-volume wards where commercial automation solutions are financially inaccessible. Experimental results demonstrate medicine identification accuracy of 96.5%, dispensing accuracy of 97.2%, and a Wi-Fi communication reliability of 98.4%, validating the system's suitability for real-world deployment.

The use of repurposed CD drive components as dispensing actuators exemplifies the project's commitment to cost-efficiency without compromising reliability. This project bridges the gap identified in the literature survey and lays a strong foundation for future enhancements including liquid medication dispensing, advanced SLAM-based robot navigation, integration with Hospital Information Systems (HIS), and AI-driven dosage optimization, contributing meaningfully to the global mission of smart, safe, and efficient healthcare delivery.

REFERENCES

- [1] S. Patel and R. Mehta, "Automated Medicine Dispensing Using Arduino," *Int. J. Embedded Syst. Appl.*, vol. 8, no. 2, pp. 45–53, 2018.
- [2] J. Kim and H. Park, "IoT-Based Smart Drug Delivery System," *IEEE Trans. Consumer Electron.*, vol. 65, no. 3, pp. 312–320, 2019.
- [3] M. Ravi and K. Srinivas, "Robotic Medicine Dispensing for Hospitals," in *Proc. ICRAM, Bangalore*, pp. 78–84, 2019.
- [4] A. Gupta and P. Singh, "Smart Healthcare System Using IoT," *J. Med. Internet Res.*, vol. 22, no. 4, e14536, 2020.

- [5] L. Zhang and Y. Wang, "Pill Dispenser with ESP8266 and Blynk App," *Int. J. Adv. Comput. Sci.*, vol. 11, no. 7, pp. 102–109, 2020.
- [6] T. Nguyen and V. Le, "Automated Pill Sorting and Dispensing Robot," *IEEE Access*, vol. 8, pp. 67231–67242, 2020.
- [7] B. Sharma and N. Joshi, "RFID-Based Medicine Dispenser for Elderly," *J. Healthcare Eng.*, vol. 2021, Art. no. 9982165, 2021.
- [8] C. Osei and D. Mensah, "Hospital Pharmacy Automation Using PLC," *African J. Eng. Res.*, vol. 9, no. 1, pp. 23–30, 2021.
- [9] R. Hussain and F. Ahmed, "Telemedicine-Integrated Drug Dispenser," *Telemedicine e-Health*, vol. 27, no. 5, pp. 567–575, 2021.
- [10] E. Santos and M. Costa, "Smart Blister Pack Management System," *Sensors*, vol. 21, no. 12, p. 4102, 2021.
- [11] P. Kumar and A. Reddy, "ESP-32 Based IoT Medicine Reminder System," *Int. J. Innov. Technol. Explor. Eng.*, vol. 11, no. 4, pp. 1–6, 2022.
- [12] W. Chen and X. Liu, "Autonomous Hospital Delivery Robot," *Robot. Auton. Syst.*, vol. 148, Art. no. 103942, 2022.
- [13] A. Okafor and C. Eze, "Machine Learning for Medicine Dispensing Errors," *J. Biomed. Inform.*, vol. 128, Art. no. 104035, 2022.
- [14] V. Mishra and S. Das, "Wearable IoT for Patient Medication Adherence," *IEEE Internet Things J.*, vol. 9, no. 14, pp. 12105–12115, 2022.
- [15] F. Ali and M. Hassan, "Cloud-Based Smart Pharmacy Management," *Health Inform. J.*, vol. 28, no. 2, 2022.
- [16] G. Patel and H. Shah, "Contactless Medicine Dispensing Post-COVID," *Int. J. Environ. Res. Public Health*, vol. 20, no. 3, p. 2314, 2023.
- [17] K. Yamamoto and T. Tanaka, "Multi-Compartment Automated Dispenser for ICU," *Crit. Care Med. Technol.*, vol. 5, no. 1, pp. 45–52, 2023.
- [18] N. Balogun and S. Adeyemi, "Blockchain for Medicine Traceability in Hospitals," *Future Gener. Comput. Syst.*, vol. 142, pp. 234–245, 2023.
- [19] R. Perez and L. Garcia, "Voice-Activated Smart Pill Dispenser," *J. Ambient Intell. Smart Environ.*, vol. 15, no. 4, pp. 389–401, 2023.
- [20] D. Krishnaswamy and P. Balaji, "AI-Driven Robotic Medicine Dispensing in Smart Hospitals," *Artif. Intell. Med.*, vol. 148, Art. no. 102738, 2024.